

HAM TIPS



A PUBLICATION OF THE RCA TUBE DIVISION

Vol. XVII, No. 3

© 1957, Radio Corporation of America

July, 1957

A TRANSISTORIZED QSO-GETTER

For 40-Meter QRP CW Operation

by E. M. Washburn, W2RG*

Many radio amateurs have expressed a keen interest in the amazing possibilities of low-power transistorized transmitters. This expressed interest has prompted the following description, so that others may join the growing ranks of QRP operators working hundreds—or even thousands—of miles on a fraction of one watt input.

The transistorized QRP transmitter illustrated and described in this article is essentially a 40-meter cw rig, using one RCA-2N140 transistor in the crystal oscillator and another in the amplifier. The transmitter is adequately powered by two 6-volt, heavy-duty dry batteries, connected in series, which are provided with a switch to permit tuning up at 6 volts. When the transmitter is operating at full load, the crystal oscillator operates at 12 volts with a collector current of 15 milliamperes, while the amplifier operates at 12 volts, 18 milliamperes. Admittedly, these inputs are *in excess* of the manufacturer's ratings and some transistors may not operate satisfactorily under these overload conditions. An RCA-VSO69 1.5-volt dry cell is used in the oscillator emitter circuit as shown in the schematic diagram.

During the Spring and Fall of 1956, the author worked 18 states, Ontario, Quebec, Puerto Rico, Windward Islands and Trans-

vaal, S. Afr.—all on 40 meters—with an antenna consisting of a single, 106-foot wire. The wire used with the author's transmitter is strung 28 feet across the basement rafters, then leaves the confines of the shack and slopes upwards for a distance of 42 feet to a flat top which is 36 feet long and 28 feet above the ground. The antenna can be voltage-fed from the amplifier or it can be fed from the antenna tuner.

Over a long period of operations, the signal reports received by the author have varied from RST-339 to 589, depending upon band conditions, distance and the type of receiver used by the receiving station. The QSO with Transvaal, S. Afr., (ZS6TR) appears to be a world record for a 40-meter low power/transistor transmitter and the contact was made without any form of prearrangement and without any previous communications using a higher-power rig. At 216 milliwatts and covering a distance of 8,000 miles, this performance is comparable to 37,000 miles per watt at a frequency of 7002 Kc.

Several contacts have been made on the 80-meter band, but the most gratifying and successful results have been accomplished in the 40-meter band. To the present, no attempt has been made to put the QRP transmitter on the 20-meter or the higher frequency bands; however, this band could be worked by using the amplifier as a doubler stage and substituting an RCA-2N247 transistor for the RCA-2N140.

*Manager, Frequency Control Engineering, RCA, Camden, N. J.



Complete transistor rig. Maximum input to the final amplifier: 216 Mw.

CONSTRUCTION

The complete transistor transmitter station comprises five units as shown in the photograph. The wave meter would normally be placed several feet away with its pickup coil about 2 inches from the antenna wire. Since this absorption wave meter is entirely conventional and the battery box is merely a housing for the two 6-volt dry batteries and the 1.5 volt dry cell, the circuit description will be limited to the crystal oscillator unit, amplifier and antenna tuner. Each of these three units is housed in a minibox which measures 5 inches by 4 inches by 3 inches. Interior construction details are shown in the photographs of each.

Although VFO circuits have been tried, the only successful operation has been with crystal control, and in this particular design the crystal unit is in the emitter circuit. The key is by-passed by a low-voltage 2 μ f capacitor to improve keying characteristics, particularly when a "bug" is used. The most critical adjustment is the location of the output tap on the base inductor to achieve stable performance, free from "birdies."

Whether or not an amplifier is used, the output tap on the tuned circuit inductor should be just far enough from the ground end for a stable signal, free from multi-vibrator type birdies when the key is first closed. In the unit described, the tap is almost at midpoint, $10\frac{1}{2}$ turns from the ground end with a total of 23 turns in the coil. The optimum location for this tap must be obtained by "cut and try" method, keeping the collector voltage low and backing down on the emitter potentiometer to avoid exceeding 15 ma collector current.

The transistorized crystal oscillator is shown with the 2N140 transistor just above the crystal unit. The lower central knob adjusts the variable tuning capacitor, while the left-hand knob is used to set the "bias" potentiometer at optimum for clean keying at full output. The switch at the lower right is the main battery on-off switch, while the jack at the lower left is for the key. On top of the unit, the coax connector is for the rf output and the four-prong male connector is for the 12-volt and 1.5-volt supplies from the battery box. The inside components of the oscillator are shown in the photograph.

In the amplifier circuit, the only critical adjustment is the location of the tap on the

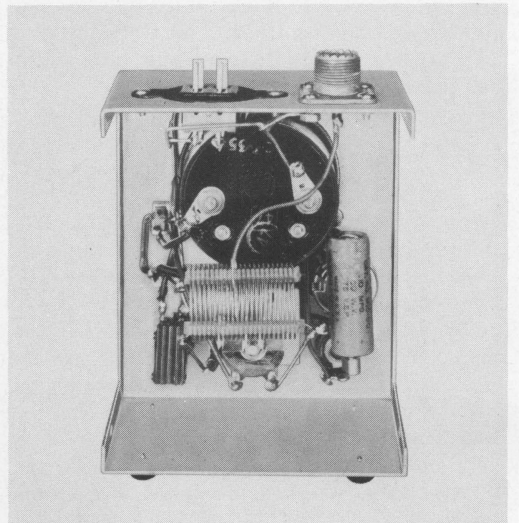

Rear view of crystal oscillator. Best dx on 40 meters was ZS6TR, 8,000 miles, Transvaal, S. Afr., without pre-arranged contact.

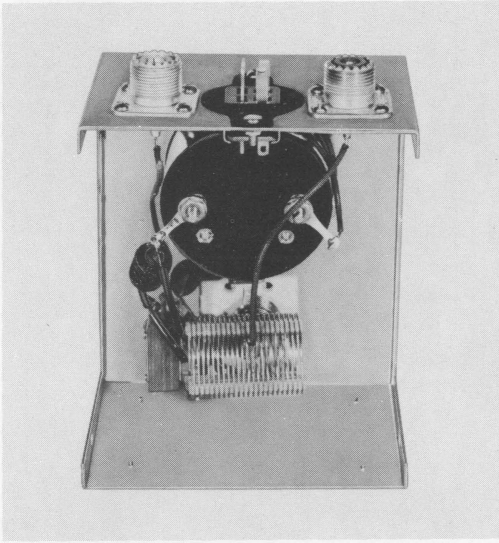

Rear view of transistor amplifier.

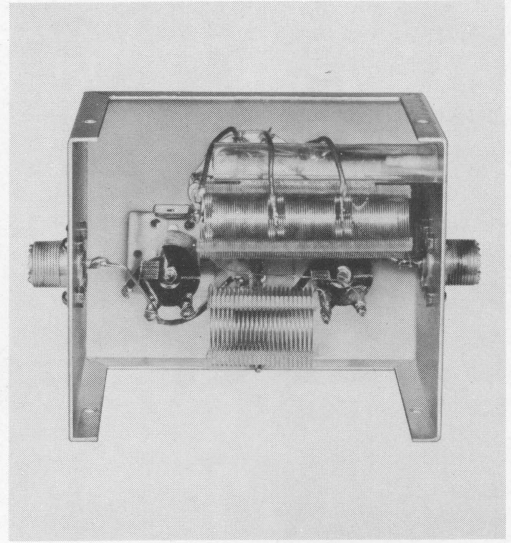

Interior view of antenna tuner.

collector tank coil. The optimum position must be found by trial, but should be near the midpoint or slightly towards the ground end. Because one set of batteries is used as the 12-volt supply for both the oscillator and amplifier, the on-off switch may be omitted since the common ground is made through the coax cable.

The use of an antenna tuner was found helpful, although not essential. The absorption wave meter, however, is considered an absolute necessity, since it gives a sensitive indication of the radiated energy. During tuning operations, this meter pickup coil may be located close enough to the antenna wire (about 6 feet from the tuner or transmitter) to give a meter reading at about half-scale, assuming that full scale is about $200 \mu\text{a}$. Then it should be removed completely or decoupled until the needle movement is just visible. Although the tuner circuit contains more components than absolutely required, it does permit precision tuning for optimum radiated power at minimum collector current, and in low power work of this particular type every individual milliwatt must be utilized to produce maximum power for maximum contacts.

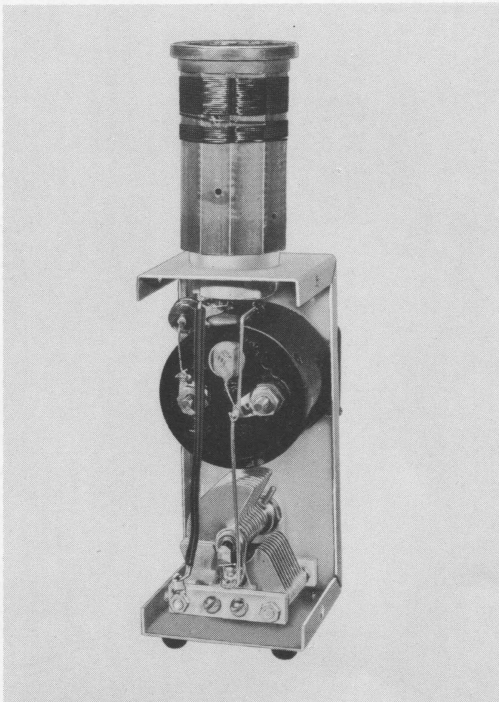

Construction details of absorption wave meter used to indicate maximum radiation from antenna.

As in conventional transmitter tuning, increasing the load will also increase the collector (plate) current, but instead of tuning the tank circuit for a dip in collector current, the more positive indication of proper loading is maximum wave meter current at minimum collector current. Maximum radiation normally will not be at maximum current in the collector circuit. Adjustment of the emitter potentiometer in the oscillator is quite critical for optimum setting.

In all tuning operations it is advisable to listen to the signal in the station receiver. As the voltage on the oscillator emitter is gradually increased and oscillation starts, the signal will sound very strong, even before there is

any indication of collector current in the amplifier. As the emitter potentiometer is advanced slowly, the oscillator collector current will increase and the keyed signal will become clean, with a slight ringing which is characteristic of crystal oscillator keying. Unfortunately, if there is any indication of radiated power under this setting of the potentiometer, it will be very small, and the emitter voltage should be further increased. At about 10 ma collector current, there should be a definite amplifier collector current and a wave meter indication of radiated power, and all tuning controls must be adjusted carefully until peak radiation is reached. During this final tuning, birdies are very liable to be heard in the receiver all over the dial, and tuning must be readjusted until the only signal heard is at the crystal frequency. If tuning alone is not effective in eliminating these spurious oscillations with a "cold" transistor, the emitter voltage in the oscillator must be reduced or the tap on its base coil moved further from the ground end.

When the keyed signal is clean and free from birdies, with collector current between 12 and 15 ma in the oscillator and 15 to 18 ma in the amplifier, and with a good indication of radiation in the absorption wave meter, that meter should be removed or coupled very loosely. The rig is then all set for normal use.

In at least one respect, however, operation will not be normal, and that is in establishing contacts. The only successful method experienced by the writer has been in answering general calls and rarely by calling CQ, CQ-TR, CQ-QRP, or any other form inviting a QSO. Experience teaches that it is well to listen for a few seconds before answering a CQ, to see if others are answering the same call. If so, it is almost a waste of time to answer, even assuming your crystal frequency is close enough to be hopeful of establishing contact. The writer has had best success by having a fair selection of crystals, choosing one which is in the least occupied portion of the band, tuning for optimum radiation at minimum power input, and waiting for someone to call CQ on that frequency. On 40 meters you don't have to wait long under normal conditions.

On 80 meters, a 2N139 may be used in place of the 2N140 and is slightly lower in price. Cutoff frequency of the 2N139 is approximately 5 Mc. The 2N140 should be used for 7 Mc operation, with its higher cutoff frequency at about 8 Mc. Future QRP rigs

hold many possibilities of higher-frequency operation, voice modulation, and increased efficiency.

Your author wishes to emphasize the importance of selecting the proper location for the tap on the oscillator coil and also on the amplifier coil. Both are extremely critical for optimum performance. The antenna tuner described will load almost any kind of wire, but obviously the better antenna system employed, the better the results will be.

Your author has never used any form of beam and all contacts, nearly 200 at this writing, have been without previous arrangement and without previous contact with higher power equipment. In the author's opinion, such "piggy-back" contacts void the attraction of the adventure in transistorized QRP amateur communications.

PARTS LIST

- B₁—Battery, 1.5-volt (RCA-VS069, or equivalent)
- B₂—Battery, 6-volt (RCA-VS009, or equivalent)
- B₃—Battery, 6-volt (RCA-VS009, or equivalent)
- C₁—2 μ f, electrolytic
- C₂—0-100 μ f, variable
- C₃—0.01 μ f
- C₄—0.01 μ f
- C₅—0-100 μ f, variable
- C₆—0.001 μ f
- C₇—0-100 μ f, variable
- C₈—0-100 μ f, variable
- C₉—0-50 μ f, variable
- C₁₀—0.001 μ f
- C₁₁—0.001 μ f
- L₁—23 turns B & W Miniductor #3015, tapped near center
- L₂—23 turns B & W Miniductor #3015, tapped near center
- L₃—23 turns B & W Miniductor #3015, tapped near center
- L₄—2 $\frac{3}{4}$ " length B & W Miniductor #3016, 3 equal taps
- L₅—Any size 40-meter pickup coil center-tapped, which tunes through band, with C₉
- M₁—0-20 dc milliammeter
- M₂—0-20 dc milliammeter
- M₃—0-100 microammeter
- R₁—100,000 ohms
- RFC₁—RF choke, 1 mh
- RFC₂—RF choke, 1 mh
- RFC₃—RF choke, 1 mh
- SW₁—SPST switch
- SW₂—SPDT switch
- SW₃—SPST switch
- SW₄—Switch, 4-position
- X—Crystal, 3.5 or 7.0 Mc
- RCA-2N140 Transistor (oscillator)
- RCA-2N140 Transistor (amplifier)
- RCA-1N34-A Semiconductor Diode (wave meter)

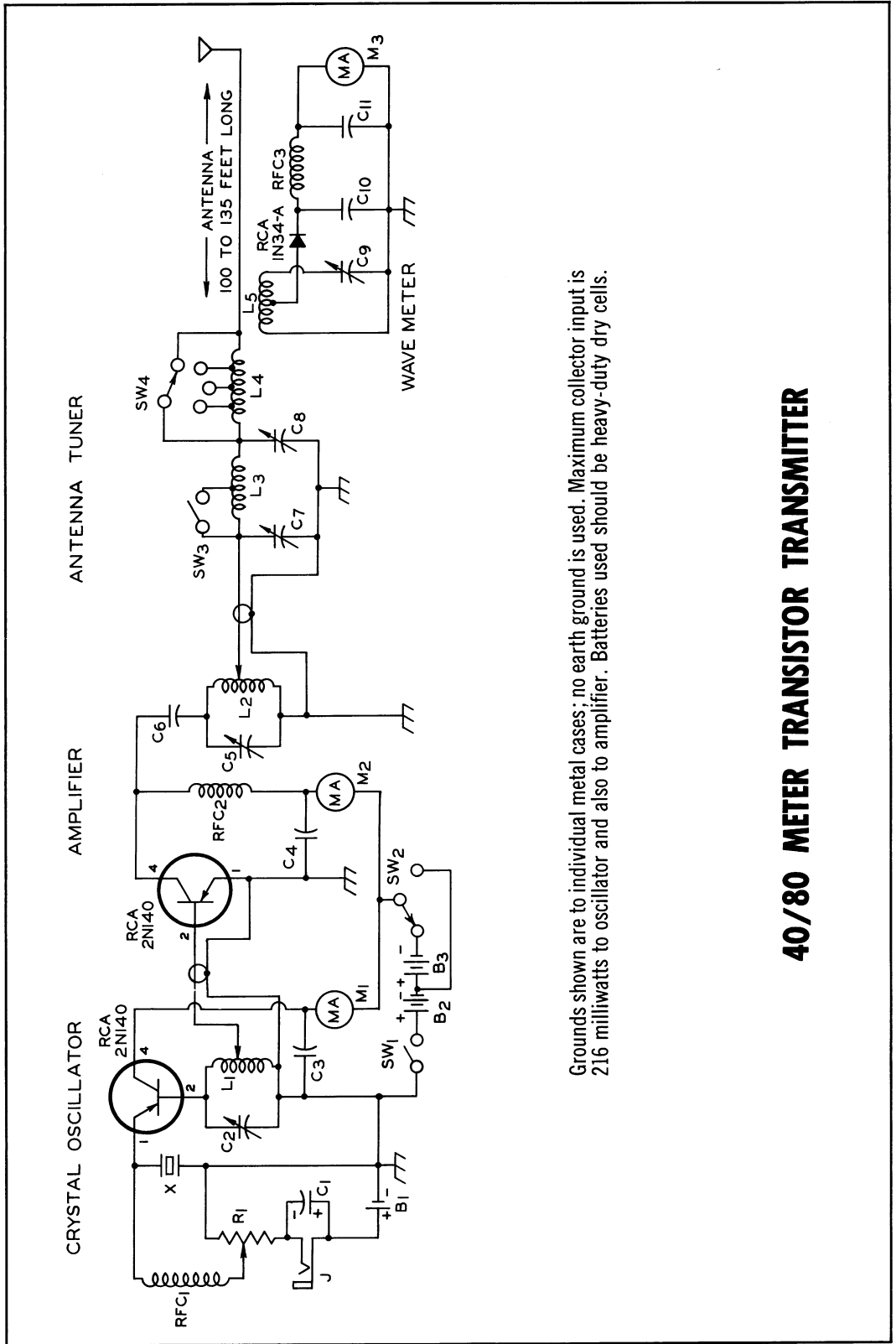

Grounds shown are to individual metal cases; no earth ground is used. Maximum collector input is 216 milliwatts to oscillator and also to amplifier. Batteries used should be heavy-duty dry cells.

40/80 METER TRANSISTOR TRANSMITTER



From your local
RCA distributor,
headquarters for
RCA receiving
and power tubes.

RCA HAM TIPS
is published by the
RCA Tube Division,
Harrison, N. J.
It is available free
of charge from
RCA Distributors.

Harvey Slovik, Editor
Robert Leedy, W2PMP
Technical Editor

FORM 3547 REQUESTED



WHEN MAILING
PLACE POSTAGE HERE

Devices and arrangements shown or described herein may use patents of RCA or others. Information contained herein is furnished without responsibility by RCA for its use and without prejudice to RCA's patent rights.



Again...

BEAM POWER TUBES PREDOMINATE!

Beam Power Tubes—an original RCA development—continue to hold top position among leading amateur and commercial equipment designers everywhere. Take the 1957 Radio Amateurs' Handbook. In this "official" amateur technical textbook, over 75% of all transmitter and modulator units described are built around beam power types.

Why is this so?

Because Beam Power Tubes fit transmitter

requirements from every angle; they take less plate voltage—require fewer driver stages—make efficient bandswitching circuits practicable—deliver a whole of a signal at low overall transmitter tube cost.

So whether you are rebuilding or "re-tubing", RCA Beam Power Tubes are your best bet. They're available in amateur power ratings to meet your needs. Get them from your local RCA Tube Distributor.



TUBES FOR AMATEURS
RADIO CORPORATION OF AMERICA
Electron Tube Division
Harrison, New Jersey